

Terms of Use

- Please read this guide carefully and keep it for future reference.
- Follow all instructions for safe use of the product and handle with care.
- Use the camera within within given temperature, humidity, voltage level noted in the specifications. And only use accessories approved by the manufacturer.
- Do not disassemble the camera.
- Avoid facing the camera directly to sunlight or strong light sources.
- Periodic cleaning may be required. Use a damp cloth only. Do not use any harsh chemical cleaners.

Disclaimer

- This camera requires a specified UL/CSA approved power supply.
- Use of a non-regulated, non-conforming power supply can damage the product and void the warranty.
- Do not submerge the camera in water. It is recommended to install it in a concealed location.
- Recordings without consent are illegal in some jurisdictions. ZOSI assumes no responsibility for any use of the product that does not comply with local laws.
- The camera includes an IR CUT that clicks when the camera switches between day/night vision modes. This sound indicates that the camera is working.

What's in the Box

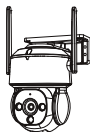

Camera×1



Power Adapter×1



Mounting Screws×1



Waterproof Lid×1



Mounting Templates×2



Quick Start Guide×1

Introduce the Camera

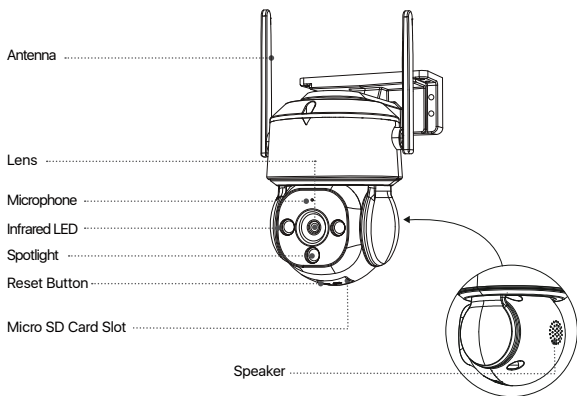

NOTE: Before installing the product, please test the product before installation. Battery cameras need to be fully charged before using.

Access the System via Smartphone or PC

1. On Smartphone

Search ZOSI Smart in App Store or scan the QR Code to download and install the App. Follow the instructions to register an account.



Zosi Smart



App(IOS/Android)

2. Add Device

3 ways to add device to Zosi Smart App via:

- Wi-Fi (Scan UID)
- Wireless Access Point (AP)
- Ethernet Cable

Please scan the QR code to watch the App operation video.



App video operation link

3. On PC

Download: <https://www.zositech.com/pages/app>

Mount the Camera

1. Installation Precautions

- Do not point the camera towards any light sources.
- Do not point the camera at glass windows or reflective objects. Otherwise, it may result in poor image performance due to reflections from infrared LEDs, ambient lights or status lights.
- Do not mount the camera in shaded area, and point the camera towards a well-lit area. For better image quality, make sure the camera and the captured subject are at the same lighting conditions.
- For optimum performance, it is recommended that the camera be installed as far away as possible from electronic devices such as microwaves, televisions, radio phones and baby monitors to prevent signal interference.
- It is recommended to clean the lens with a soft cloth from time to time.
- Do not expose the power port to water or moisture, or blocked by dirt or other things.
- Do not install the camera where rain and snow may hit the lens directly.
- Camera may work in extremely cold conditions as low as -10°C as it will produce heat when powered on. You may power the camera indoors for a few minutes before installing it outdoors. (Only for outdoor cameras)

2. Mount the Camera to the Wall

Drill holes according to the mounting template.

NOTE: Use the anchors included in the package if needed.

Attach the camera bracket with screws included in the package.

NOTE: Run the cables through the cable notch on the mounting base. For WiFi cameras, it is recommended to mount the antenna upward or horizontally for better WiFi connection.

2.1. Wall mounting

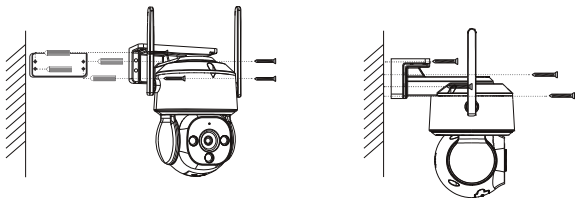

2.2. Ceiling mounting

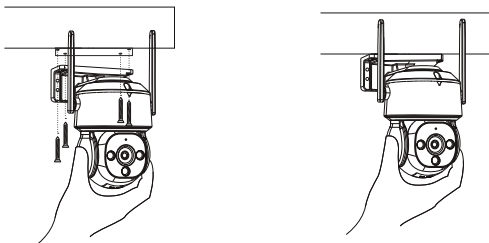

3. Installation Distance, Height and Angle

Distance: Best accuracy for objects within 5-50 ft (1.5-15 m).

Angle: Tilt the camera down about 30°-60° from the horizontal position.

Height: Install the camera 8-16 ft (2.5-5m) above the ground.

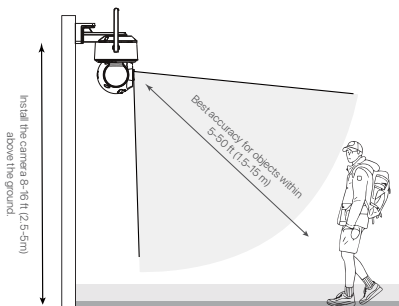

NOTE: The accuracy of human detection will be affected by various factors, such as the distance between the person and the camera, the height of the person, the height and angle of the camera, etc. The accuracy and distance of detection will also be affected in the night vision environment.

FAQs

1. Camera can not Turn on

If your camera doesn't turn on, please try the following solutions:

- Please plug the camera into another outlet to check whether it works.
- Please use another 12V power adapter to check whether it works.

If the problem persists, please contact Zositech Support: <https://support.zositech.com>

2. WiFi Connection Fails during Initial Installation

If the camera cannot connect to WiFi, please follow the troubleshooting tips listed below:

- Make sure you have entered the correct WiFi password.
- Move your camera close to the router to ensure a strong WiFi signal;

If the problem persists, please contact Zositech Support: <https://support.zositech.com>

3. Frequent Disconnection

- Please check whether the connected network works normally.
- When installing the camera, it is recommended not to be too far from the router, or use it in a place with weak WiFi signal,
- Check whether the device version is the latest version. If not, please update to the latest version;

If the problem persists, please contact Zositech Support: <https://support.zositech.com>

4. Does the camera support motion detection and image capture?

It captures images automatically when people, cars, are detected or when there is a change in detected images. Users can also manually capture images using our ZOSI Smart APP.

Notification of Compliance

1. FCC Compliance Statement

This device complies with Part 15 of the FCC Rules. Operation is subject to the following two conditions:

- (1) This device may not cause harmful interference,
- (2) This device must accept any interference received, including interference that may cause undesired operation.

2. CE Simplified EU Declaration of Conformity

ZOSI declares that product is in compliance with the essential requirements and other relevant provisions of Directive 2014/53/EU. POE cameras comply with Directive 2014/EU.

3. Correct Dispose of this product

This marking indicates that this product should not be disposed with other household waste throughout the EU. To prevent harm to the environment or human health from uncontrolled waste disposal and promote the sustainable reuse of material resources, please recycle it responsibly. To return your used device, please use the return and collection system or contact the retailer from whom the product was purchased. They can take this product for environmentally safe recycling.

Support

Visit zositech.com for the latest information and resources: Find product guides, how-to videos, troubleshooting and FAQs. Contact us at service@zositech.com