

## Terms of Use

- Please read this guide carefully and keep it for future reference.
- Follow all instructions for safe use and handling of the product.
- Use the camera within the given temperature, humidity and voltage level noted in the specifications. And only use accessories approved by the manufacturer.
- Do not disassemble the camera.
- Avoid pointing the camera directly to sunlight or any strong light source.
- Periodic cleaning may be required. Use a damp cloth only. Do not use any corrosive or chemical-based cleaners.

## Disclaimer:

- This camera requires the use of a UL/CSA-approved power supply.
- The use of non-compliant or unqualified power supplies may result in product damage and void the warranty.
- The product should not be immersed in water. It is recommended to install it in a concealed location.
- Unauthorized audio recording may be illegal in certain jurisdictions. ZOSI assumes no responsibility for any use of the product that violates local laws.
- This camera features an IR CUT. A clicking sound may be heard when the camera switches between day/night modes. This sound is a normal operation indication of the camera.

# What's in the Box

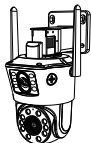

Camera



Power Adapter

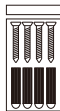

Mounting Screws



Warning Stickers



Mounting Templates



Quick Start Guide



Waterproof Lid

NOTE: Actual accessories are subject to the model you purchased.

# Camera Introduction

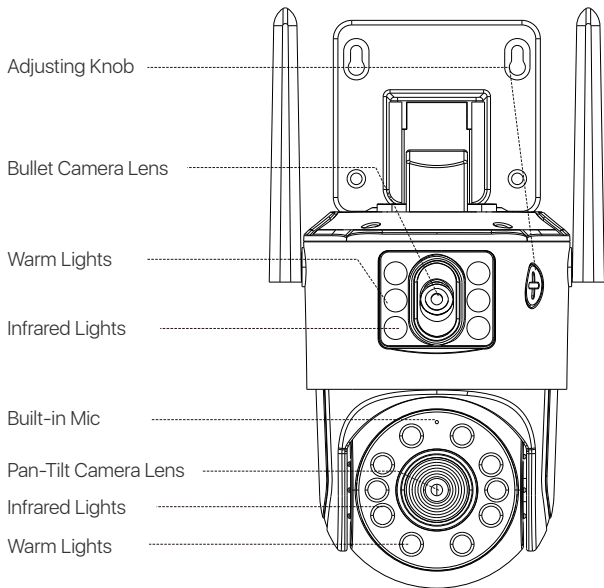

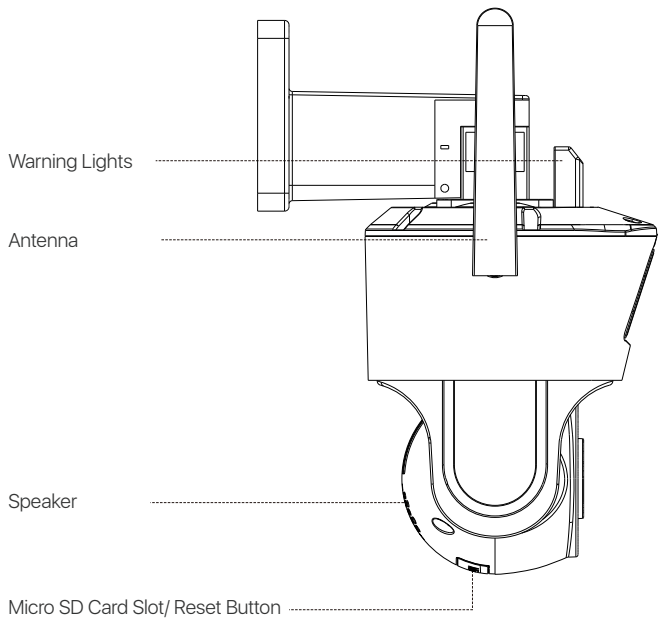

NOTE: Actual product may vary in appearance.

# App/Client Installation

## Smartphone

Search Zosi Smart in App Store or scan the QR Code to download and install the App. Follow the instructions to register an account.



Zosi Smart



Android/iOS

## PC

Download and install Zosi AVSS Client, and following this guide to complete installation. Official download link: <https://www.zositech.com/app/>, double-click "AVSS" icon, choose language and click log in.

Note: It is recommended to log in with the account of Zosi Smart App to avoid multiple accounts using. Please scan the QR code below to watch the AVSS operation video.



# Add Device

1. Open Zosi Smart App and follow the prompts to register and log in.
2. Tap "+" to add a device. Follow the in-app instructions to complete the network settings and addition of the device.

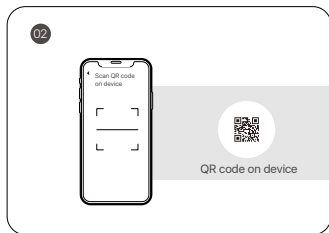
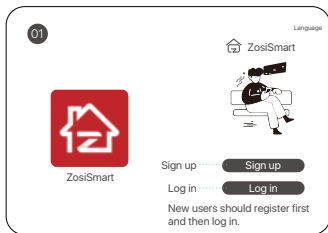

## Installation Video:



# Install the Camera

## Installation Precautions

- Do not face the camera to any light source.
- Do not point the camera at glass windows or reflective objects. Otherwise, it may result in poor image performance due to reflections from infrared LEDs, ambient lights or status lights.
- Do not mount the camera in shaded area, and point the camera towards a well-lit area. For better image quality, make sure the camera and the captured subject are at the same lighting conditions.
- It is recommended that the camera be installed as far away as possible from electronic devices such as microwaves, televisions, radio phones and baby monitors to prevent signal interference.
- It is recommended to clean the lens with a soft cloth from time to time. Make sure the power port is not exposed to water or moisture, or blocked by dirt or other things.
- Do not install the camera where rain and snow may hit the lens directly.
- Camera may work in extremely cold conditions as low as  $-20^{\circ}\text{C}$  as it will produce heat when powered on. You may power the camera indoors for a few minutes before installing it outdoors. (Only for outdoor cameras)

# Install the Camera

## NOTE:

1. Set up the network before installing the camera.
2. Run the cables through the cable notch on the mount base before installing the camera.

## A Mount the Camera to the Wall

1. Drill holes according to the mounting template and insert the anchors.
2. Install the mount base with screws.
3. Install the top bracket of the camera to the base and tighten the knob of the camera bracket.
4. To adjust the camera direction, you may control the camera to pan and tilt via Zosi App or Client.

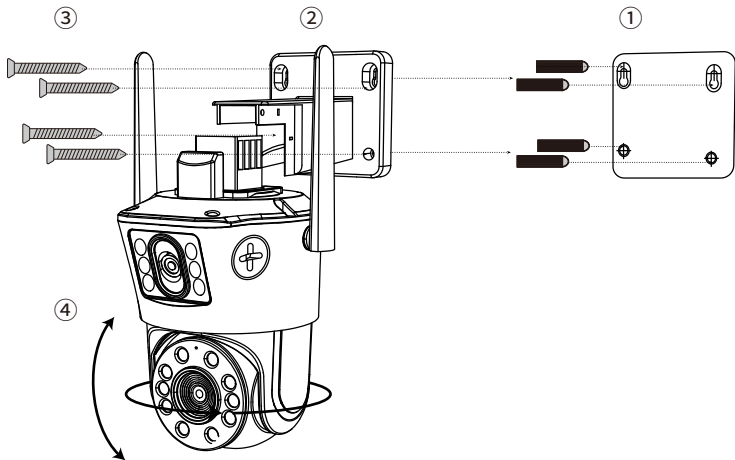



## B Mount the Camera to the Ceiling

1. Drill holes according to the mounting template and insert the anchors.
2. Install the mount base with screws.
3. Install the top bracket of the camera to the base and tighten the knob of the camera bracket.
4. To adjust the camera direction, you may control the camera to pan and tilt via Zosi App or Client.

The camera installation video is as follows:

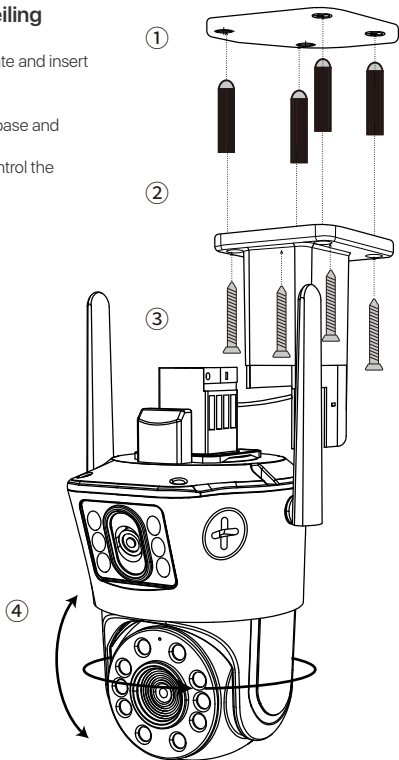

# Installation Distance, Height and Angle

Distance: Best accuracy for objects within 5-50 ft (1.5-15 m).

Angle: Tilt the camera down about 30°-60° from the horizontal position.

Height: Install the camera 8-16 ft (2.5-5m) above the ground.

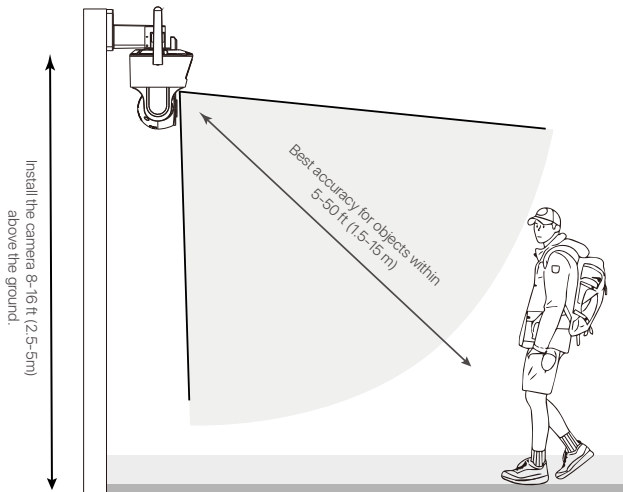

# FAQ

## **Q: Why is the device offline?**

- Confirm if the correct Wi-Fi password was entered during camera pairing. If unsure, perform a reset and retry the pairing process.
- Verify that your current network operates on the 2.4GHz Wi-Fi frequency, as this camera does not support the 5GHz Wi-Fi.
- Check if the device is connected to the network, ensure your router is functioning normally for internet access, and that the router has automatic IP address allocation enabled.

## **Q: No recording is found?**

- Check if the Micro SD card is damaged and if the date being searched for is valid. Ensure that the device's system setting time is correct.

## **Q: Why is the two-way audio not working?**

- Please check whether App permissions are allowed when installing the app on your phone.
- Verify the current network status of both the camera and your phone.
- Ensure that the current intercom camera's volume is not too low; adjust the speaker volume as needed.

## **Q: Does the camera support motion detection and image capture?**

- The camera automatically captures images when it detects people, cars, or any changes in the detected image.
- Users can also manually capture images using the Zosi Smart App.

# Notification of Compliance

## 1. FCC Compliance Statement

This device complies with Part 15 of FCC Rules.

Operation is subject to the following two conditions:

- (1) This device may not cause harmful interference.
- (2) This device must accept any interference received, including interference that may cause undesired operation.

## Simplified EU Declaration of Conformity

ZOSI declares that the device is in compliance with the essential requirements and other relevant provisions of Directive 2014/53/EU.



### Correct Disposal of this Product

This marking indicates that this product cannot be disposed with other household wastes throughout the EU. To prevent possible harm to the environment or human health from uncontrolled waste disposal and promote the sustainable reuse of material resources, please recycle it responsibly. To return your used device, please visit the Return and Collection System or contact the retailer from whom the product was purchased. They can take this product away for environmentally safe recycling.