

What's in the Box

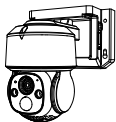

Camera



USB Charging Cable

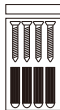

Mounting Screws



Warning Stickers



Mounting Templates



Quick Start Guide

NOTE: Actual accessories are subject to the model you purchased.

Camera Introduction

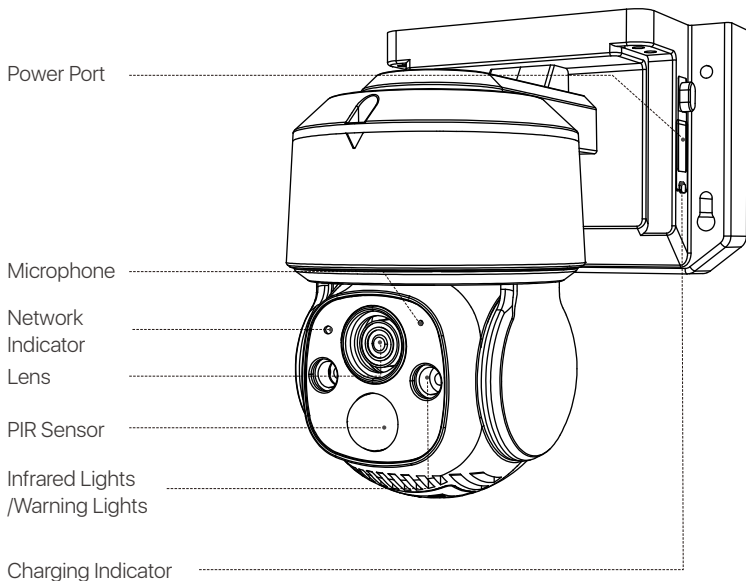

NOTE: Actual product may vary in appearance.

Initial Use

1. Insert your micro SD card.

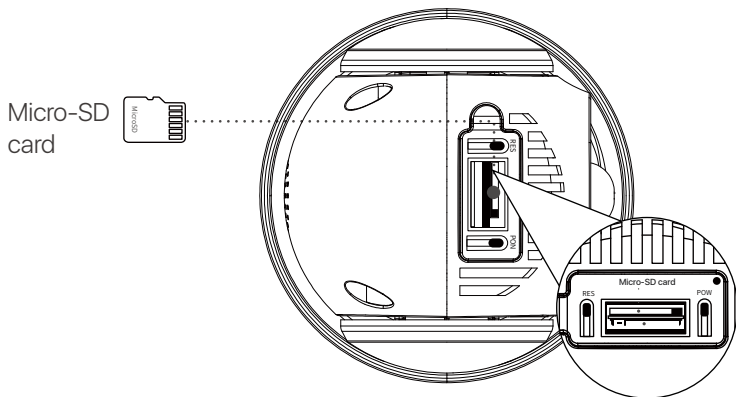

2. Charging

NOTE: The device comes with a partial charge from the factory. Please fully charge the device before initial use.

POWER Switch	Hold 3-5 seconds Turn ON/OFF
RESET Button	Hold 3-5 seconds Device Reset
Network Status Indicator	
Slow Flashing Red Light	Waiting for connection
Fast Flashing Red Light	Device's connecting
Solid Blue Light	Connection succeeded
Charging Indicator	
Solid Red Light	Camera's charging
Solid Blue Light	Camera's fully charged

App/Client Installation

Smartphone

Search Zosi Smart in App Store or scan the QR Code to download and install the App. Follow the instructions to register an account.



Zosi Smart



Android/IOS



App Operation Video

Add Device

1. Open Zosi Smart App and follow the prompts to register and log in.
2. Tap "+" to add a device. Follow the in-app instructions to complete the network settings and addition of the device.

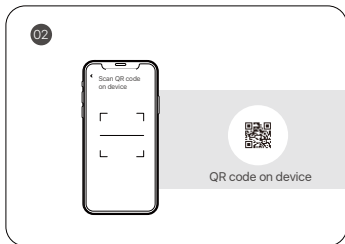
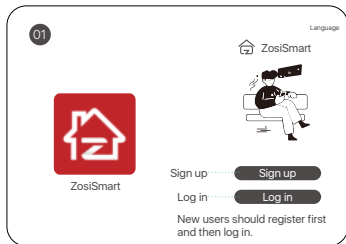

NOTE: The Wi-Fi version of the camera only supports 2.4GHz Wi-Fi. Please select Wi-Fi without "5GHz", and make sure the Wi-Fi name does not contain any special characters.

PC

Download and install the AVSS client on your computer, and follow this guide to finish the installation.

Official download link: <https://www.zositech.com/pages/app>

Double-click the "AVSS" icon, choose your language, and log in.

NOTE: It is recommended to log in with the Zosi Smart App account to avoid using multiple accounts. .

Scan the QR code below to watch the AVSS operation video.



Install the Camera

NOTE:

Set up the network and add the camera to the App before installing the camera.

A Mount the Camera to the Wall

1. Drill holes according to the mounting template and insert the anchors.
2. Install the mount base with screws.
3. To adjust the camera direction, you may control the camera to pan and tilt via Zosi App or Client.

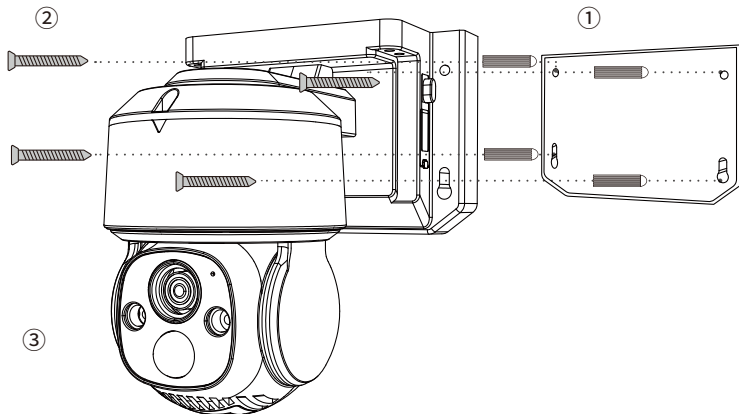

B Mount the Camera to the Ceiling

1. Drill holes according to the mounting template and insert the anchors.
2. Install the mount base with screws.
3. To adjust the camera direction, you may control the camera to pan and tilt via Zosi App or Client.

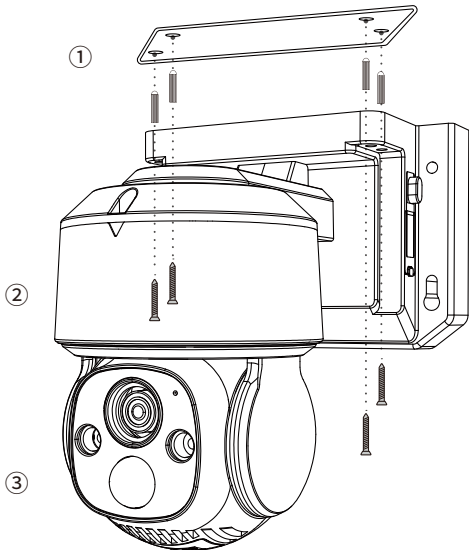

Installation Distance, Height and Angle

Distance: Best accuracy for objects within 5-33ft (1.5-10 m).

Angle: Tilt the camera down about 30°-60° from the horizontal position.

Height: Install the camera 5-11.5ft (1.5-3.5m) above the ground.

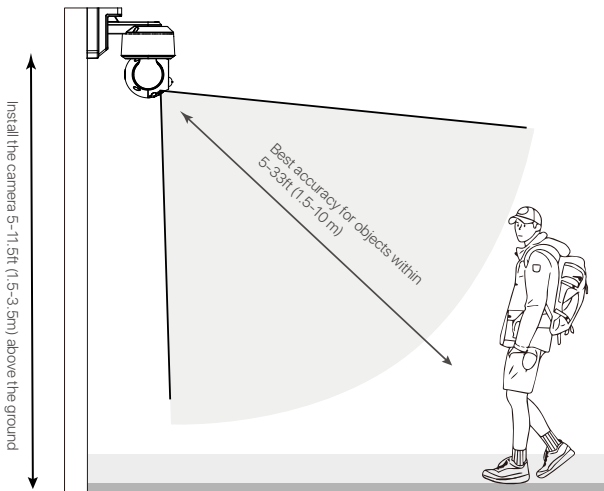

Installation Precautions

- Do not face the camera to any light source.
- Do not point the camera at glass windows or reflective objects. Otherwise, it may result in poor image performance due to reflections from infrared LEDs, ambient lights or status lights.
- Do not mount the camera in shaded area, and point the camera towards a well-lit area. For better image quality, make sure the camera and the captured subject are at the same lighting conditions.
- It is recommended that the camera be installed as far away as possible from electronic devices such as microwaves, televisions, radio phones and baby monitors to prevent signal interference.
- It is recommended to clean the lens with a soft cloth from time to time. Do not expose the power port to water or moisture, or blocked by dirt or other things.
- Camera may work in extremely cold conditions as low as -20°C as it will produce heat when powered on. You may power the camera indoors for a few minutes before installing it outdoors. (Only for outdoor cameras)

FAQ

Q: Why is the WiFi version of the device offline?

- Please verify that the Wi-Fi password entered during the camera pairing process is correct. If unsure, perform a reset and retry the pairing process.
- Verify that your current network is running on the 2.4GHz Wi-Fi frequency as this camera does not support 5GHz Wi-Fi.
- Check if the device is connected to the network, make sure the router is functioning properly to access the Internet, and make sure automatic IP address assignment is enabled on the router.

Q: No recording is found?

- Check if the Micro SD card is damaged and if the date being searched for is valid. Ensure that the device's system setting time is correct.

Q: Why is the two-way audio not functioning?

- Please check whether App permissions are allowed while installing the App on your phone.
- Confirm the current network status of both the camera and mobile phone.
- Ensure the speaker volume of the intercom camera is not too low. Adjust the speaker volume as needed.

Q: Does the camera support motion detection and image capture?

- The camera automatically captures images when it detects people, cars, or any changes in the detected image.
- Users can also manually capture images using the Zosi Smart App.

Notification of Compliance

1. FCC Compliance Statement

This device complies with Part 15 of FCC Rules.

Operation is subject to the following two conditions:

- (1) This device may not cause harmful interference.
- (2) This device must accept any interference received, including interference that may cause undesired operation.

Simplified EU Declaration of Conformity

ZOSI declares that the device is in compliance with the essential requirements and other relevant provisions of Directive 2014/53/EU.



Correct Disposal of this Product

This marking indicates that this product cannot be disposed with other household wastes throughout the EU. To prevent possible harm to the environment or human health from uncontrolled waste disposal and promote the sustainable reuse of material resources, please recycle it responsibly. To return your used device, please visit the Return and Collection System or contact the retailer from whom the product was purchased. They can take this product away for environmentally safe recycling.

NOTE: This equipment has been tested and found to comply with the limits for a Class B digital device, pursuant to part 15 of the FCC Rules. These limits are designed to provide reasonable protection against harmful interference in a residential installation. This equipment generates, uses and can radiate radio frequency energy and, if not installed and used in accordance with the instructions, may cause harmful interference to radio communications. However, there is no guarantee that interference will not occur in a particular installation. If this equipment does cause harmful interference to radio or television reception, which can be determined by turning the equipment off and on, the user is encouraged to try to correct the interference by one or more of the following measures:

- Reorient or relocate the receiving antenna.
 - Increase the separation between the equipment and receiver.
 - Connect the equipment into an outlet on a circuit different from that to which the receiver is connected.
 - Consult the dealer or an experienced radio/TV technician for help
- Changes or modifications not expressly approved by the party responsible for compliance could void the user's authority to operate the equipment.

This device complies with Part 15 of the FCC Rules. Operation is subject to the following two conditions:

- (1) this device may not cause harmful interference, and
- (2) this device must accept any interference received, including interference that may cause undesired operation.

RF Exposure Warning Statements:

This equipment complies with FCC radiation exposure limits set forth for an uncontrolled environment. This equipment shall be installed and operated with minimum distance 20cm between the radiator & body.

This device contains licence-exempt transmitter(s)/receiver(s) that comply with Innovation, Science and Economic Development Canada's licence-exempt RSS(s). Operation is subject to the following two conditions:

- (1) This device may not cause interference.
- (2) This device must accept any interference, including interference that may cause undesired operation of the device.

L'émetteur/récepteur exempt de licence contenu dans le présent appareil est conforme aux CNR d'Innovation, Sciences et Développement économique Canada applicables aux appareils radio exempts de licence. L'exploitation est autorisée aux deux conditions suivantes :

- (1) L' appareil ne doit pas produire de brouillage;
- (2) L' appareil doit accepter tout brouillage radioélectrique subi, même si le brouillage est susceptible d' en compromettre le fonctionnement.

Radio Frequency Exposure Statement for IC

This equipment complies with IC exposure limits set forth for an uncontrolled environment. The device can be used in portable exposure conditions. This equipment shall be installed and operated with minimum distance 20cm between the radiator & body.

Cet équipement est conforme aux limites d'exposition IC établies pour un environnement non contrôlé. L'appareil peut être utilisé dans des conditions d'exposition portables. Cet équipement doit être installé et utilisé avec une distance minimale de 20 cm entre le radiateur et le corps.