

**ZOSI**  
PROFESSIONAL SECURITY MADE EASY

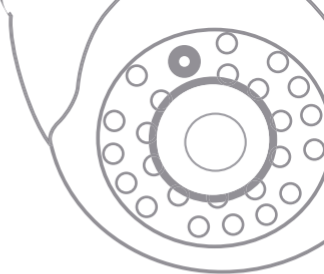

# Security Camera

## Day/Night

Instruction Manual ---- 1  
Mode d'emploi ---- 10  
Deutsche Anleitung ---- 19  
Guía de Instalación ---- 28  
Guida rapida all'uso --- 37  
Snelstartgids --- 46

## **Statement**

Thank you for purchasing this product. ZOSI is committed to providing our customers with a high quality, reliable security solution. ZOSI cannot assume responsibility for any consequences resulting from the use thereof.

## **Before Installation**

This product require cabling. It is strongly suggested to test all products and parts before installation and cabling.

## **Installation Video**

<https://youtu.be/YUf6wVbK0Wk>

## **Tech Support**

Website: [www.zositech.com](http://www.zositech.com) Email: [service@zositech.com](mailto:service@zositech.com)

## Product Overview

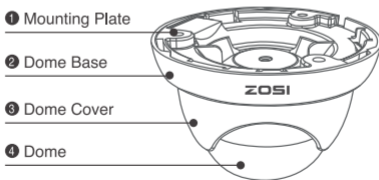
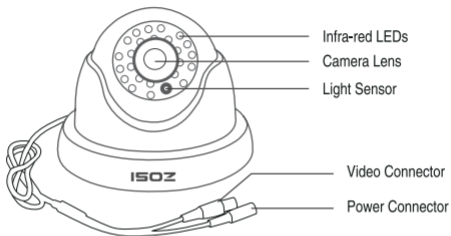

## Mounting your camera

Step 1: Separate the **1 Mounting Plate** from **2 Dome Base** by twisting the Mounting Plate in a counterclockwise motion.

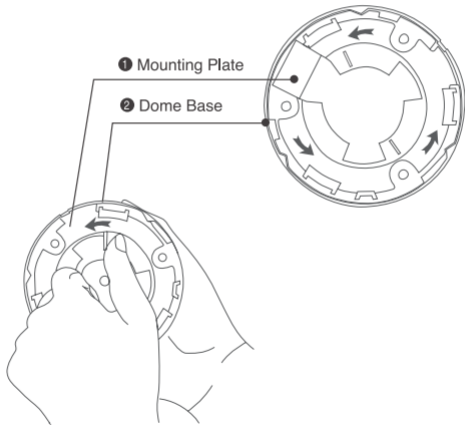

Step 2: Remove the **② Dome Base**.

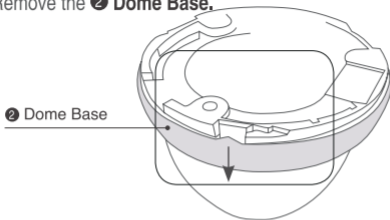

Step 3: Remove the **③ Dome Cover** and **④ Dome**.

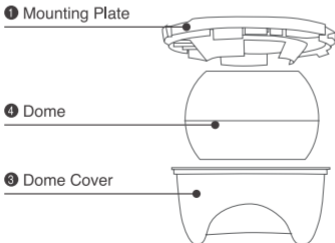

Step 4: Install the **1 Mounting Plate** to the ceiling or wall in the position with the supplied screws.

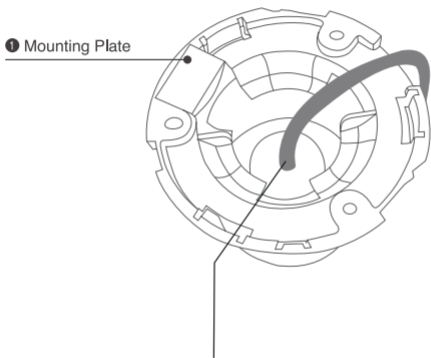

**Note:** The cable should be though the Mounting Plate.

Step 5: Attach the **4 Dome** and **3 Dome Cover** to the **1 Mounting Plate**.

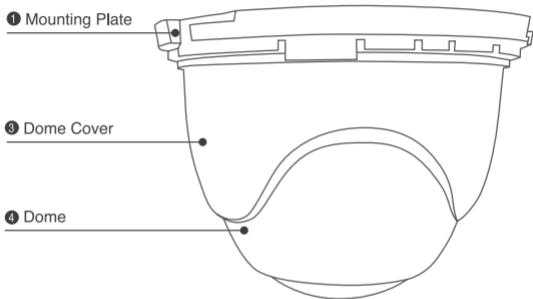

Step 6: Attach the **② Dome Base** to the **① Mounting Plate**, then twisting Dome Base in a counterclockwise motion until hear the “lock” sound.

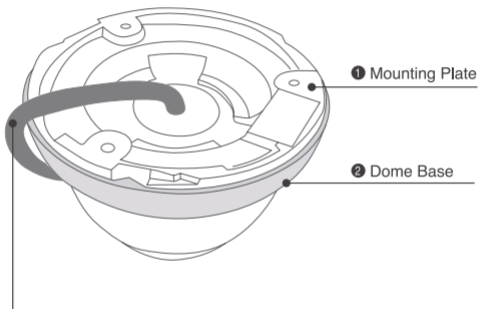

**Note:** The cable should be fixed on the slot hole.



## Positioning the cables

Please note, model shown is for illustration purposes only.

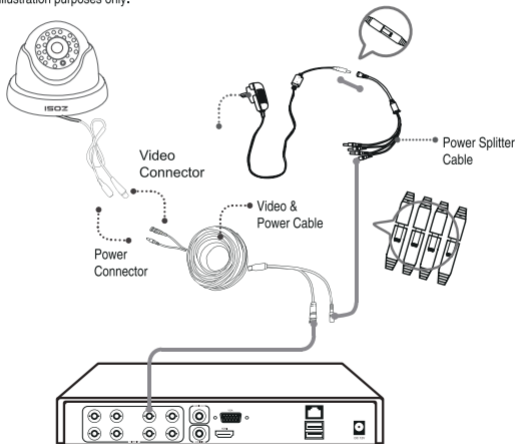

## Troubleshooting

Q: Video Loss appears where the image from my camera should be displaying on my DVR?

1. Check the extension cable (power and video) is securely connected to the camera.
2. Check the video output from the camera is securely connected to a video input channel on the DVR.
3. Check the power from the camera is securely connected to a power supply.

Q: When I view an image from the camera at night I only see a bright spot and no image?

A: A reflection can be caused in night vision mode if the camera is looking through a window. At night, the infrared light the camera uses to see in the dark can 'bounce back' off a reflective surface (such as glass, water, spider webs, some ceramics and so on) and effectively blind the camera. If you want to see outside, mount the camera outside - we made it weatherproof for a reason!

Q: The BNC extension cable will not connect to my TV?

A: Many TV's and monitors do not have a BNC connector but do have an RCA connector. Connect a BNC to RCA adapter to the end of the extension cable and then plug into the RCA video input on your TV or monitor.